



FOOD WARMERS {MERCHANDISERS} POUCHED PRODUCT, ADVANTAGE™

Model FSAF

Date:

Project:

Quantity:

Item Number:



FSAF 85070



Warranty

Server Products equipment is backed by a two-year limited warranty against defects in materials and workmanship. For a copy of our complete warranty statement, see our web site or contact us.

Bid Description

The Food Server Advantage™ is available in (2) models for dispensing fudge or caramel. Advantage™ units are constructed of a stainless steel enclosure with a brushed (#4) finish, ABS plastic lid and high-temperature molded top. Pump is stainless steel with welded construction. Each unit includes a magnetic sign for merchandising.

An adjustable precalibrated thermostat controls twin heating elements cast in the food vessel. A third heating element is bonded to the aluminum paddle plates. The central paddle is located between (2) #10 pouches. Each unit includes a spout warmer.

Temperature settings are marked on the thermostat knob. Power is controlled with an ON/OFF rocker switch. An interlock switch cuts power to paddle when the lid is removed.

Capacity is (2) #10 pouches (3 qt, 2.8 L) with fitment. Pump valve features captured stainless steel balls. Maximum stroke yields 1 ounce (30 mL) with gauging collars supplied to reduce yield in ¼ ounce (7 mL) increments. Exclusively uses a Cryovac® pouch with fitment.

Standard Features

Closed, sanitary system dispenses from (1) pouch while warming a second pouch to serving temperature

Outside of pump remains clean

Evacuation*: 96% fudge, 97% caramel

Pump design prevents loss of valve balls

Portion control pump offers 1, ¾, ½, and ¼ oz servings

Magnetic merchandising sign attracts attention

Food Server Advantage™ Accessories

- Cylinder-side cleaning brush 82049
- Spout-side/cast valve cleaning brush 82526

Specifications on reverse side



Model FSAF

FOOD WARMERS {MERCHANDISERS} POUCHED PRODUCT, ADVANTAGE™

Food Server Advantge™

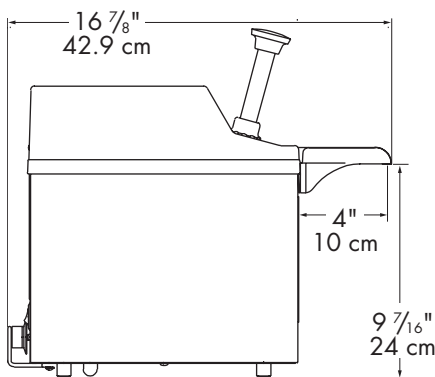
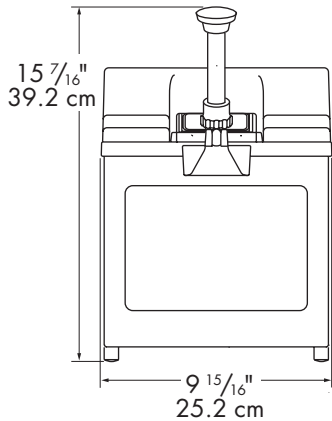

Specifications

Model	FSAF 85070 Fudge												
Construction	Stainless steel enclosure, ABS plastic lid, and high-temperature molded top. Stainless steel pump with welded construction. Pump design prevents loss of valve balls. Includes magnetic Fudge sign.												
Capacity	(2) #10 pouches of 3 quarts each, 6 quart total (or 2.8 L each, 5.6 L total)												
Dimensions	<table border="1"> <thead> <tr> <th></th> <th>Height</th> <th>Width</th> <th>Depth</th> </tr> </thead> <tbody> <tr> <td>in</td> <td>15 7/16</td> <td>9 15/16</td> <td>16 7/8</td> </tr> <tr> <td>cm</td> <td>39.2</td> <td>25.2</td> <td>42.9</td> </tr> </tbody> </table>		Height	Width	Depth	in	15 7/16	9 15/16	16 7/8	cm	39.2	25.2	42.9
	Height	Width	Depth										
in	15 7/16	9 15/16	16 7/8										
cm	39.2	25.2	42.9										
Electrical	120V, 60Hz, 450W, 3.8A 72 in (183 cm) cord set NEMA 5-15P, 15A, 125V PLUG												
Weight	28 lb (12.7 kg)												
Option	FSAF 85080 Caramel. Same as FSAF (85070) described above, except with Caramel magnetic sign.												

Cryovac® is a registered trademark and a trade name of Cryovac Inc.

FOB Richfield, Wisconsin 53076

NSF Listed as a rethermalization unit to ensure food is quickly heated to a safe temperature before bacteria has an opportunity to grow.

CAD Library

Individual CAD images can be downloaded from product pages on our web site. We are also a member of The KCL CADalog with more than 100 other manufacturers. Our complete collection of CAD files can be purchased through Kochman Consultants, Ltd. at kclcad.com.

* Test results on file

