



# FOOD WARMERS {HOT TOPPING} CONE DIP WARMERS

Models DI-1  
DI-2, DI-3

Date:

Project:

Quantity:

Item Number:



**DI-2 92020**



## Warranty

Server Products equipment is backed by a two-year limited warranty against defects in materials and workmanship. For our complete warranty statement, see our web site or contact us.

## CAD Library

Individual CAD images can be downloaded from product pages on our web site. We are also a member of The KCL CADalog with more than 100 other manufacturers. Our complete collection of CAD files can be purchased through Kochman Consultants, Ltd. at [kclcad.com](http://kclcad.com).

## Bid Description

All stainless steel construction with a brushed (#4) finish. Dip servers have a removable bottom and top and feature a hinged lid. Flanges in top extend down into the jar to prevent dripping into warmer. We recommend dipping from our NSF approved stainless steel jar (not included). Your local jurisdiction may not permit dispensing from a #10 can. The hinged lid stays open for dipping.

Adjustable precalibrated thermostat controls a tubular heating element. Heats by natural convection through air. Temperature settings—marked as low or high—range from 50° F (10° C) to 150° F (66° C).

DI-1 capacity is (1) Stainless Steel Jar (94009) or #10 can. The 100 watt heating element is thermostatically controlled.

DI-2 capacity is (2) Stainless Steel Jars (94009) or #10 can. The 120 watt heating element is thermostatically controlled.

DI-3 capacity is (3) Stainless Steel Jars (94009) or #10 cans. The 180 watt heating element is thermostatically controlled.

## Standard Features

All stainless steel construction for durability

Hinged lid stays open for dipping convenience

Removable top and bottom for easy cleaning

Flanges in top prevent dripping into warmer and hold the can or jar in place

Adjustable precalibrated thermostat for accurate heat control

Tubular heating element provides heat through natural convection to eliminate water-bath

Temperature marks on knob with protective knob guard

## Food Server/Cooker Accessory

3 quart (2.8 L) Stainless Steel Jar 94009

Storage Lid for Stainless Steel Jar 94008

Specifications on reverse side



# FOOD WARMERS {HOT TOPPING} CONE DIP WARMERS

Models DI-1  
DI-2, DI-3

## Dip Servers

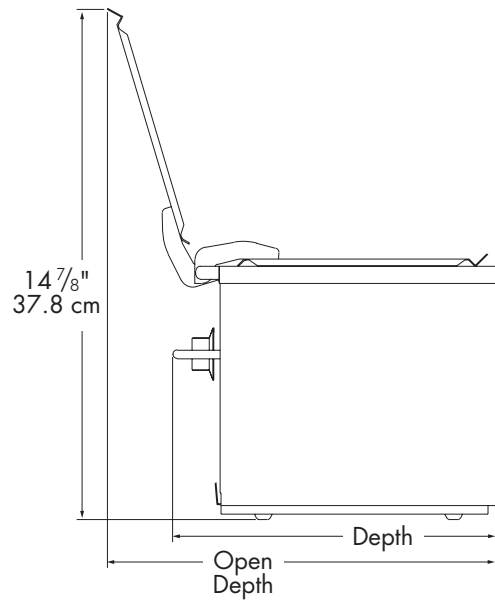
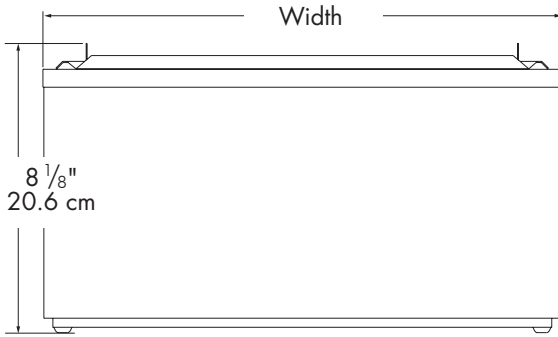

## Specifications

<b>Model</b>	<b>DI-1 92000</b>			
Construction	All stainless steel with a brushed (#4) finish.			
Capacity	(1) stainless steel jar or #10 can holds 3 quarts (2.8 L).			
Dimensions	<u>Height</u>	<u>Width</u>	<u>Depth</u>	<u>Open Depth</u>
	in 8 1/8	7 5/8	9 11/16	11 9/16
	cm 20.6	19.4	24.6	29.4
Electrical	120V, 60Hz, 100W, .8A 72 in (183 cm) cord set NEMA 5-15P, 15A, 125V PLUG			
Ship Weight	7 lb (3.2 kg)			
<b>Model</b>	<b>DI-2 92020</b>			
	Same as above except:			
Capacity	(2) stainless steel jars or #10 cans hold 3 quarts (2.8 L) each; 6 quart (5.7 L) total.			
Dimensions	<u>Height</u>	<u>Width</u>	<u>Depth</u>	<u>Open Depth</u>
	in 8 1/8	14 5/8	9 7/16	11 5/16
	cm 20.6	37.1	24	28.7
Electrical	120V, 60Hz, 120W, 1A			
Ship Weight	9 lb (4.1 kg)			
<b>Model</b>	<b>DI-3 92040</b>			
	Same as above except:			
Capacity	(3) stainless steel jars or #10 cans hold 3 quarts (2.8 L) each; 9 quart (8.5 L) total.			
Dimensions	<u>Height</u>	<u>Width</u>	<u>Depth</u>	<u>Open Depth</u>
	in 8 1/8	21 5/8	9 7/16	11 5/16
	cm 20.6	55	24	28.7
Electrical	120V, 60Hz, 180W, 1.5A			
Ship Weight	12 lb (5.4 kg)			

FOB Richfield, Wisconsin 53076



Server Products, Inc. • P.O. Box 98 • Richfield, WI 53076 • Toll Free: 800-558-8722  
P: 262-628-5600 • F: 262-628-5110 • spsales@server-products.com • server-products.com

Server Products, Inc. reserves the right to modify specifications without obligation. Printed in USA

10-2008/.1M Stock #02007